

Superb Vac DENTAL VACUUM SYSTEM

Model Numbers: WV3, WV3R, WV5, WV5R, WV6, WV6R, WV10, WV10R

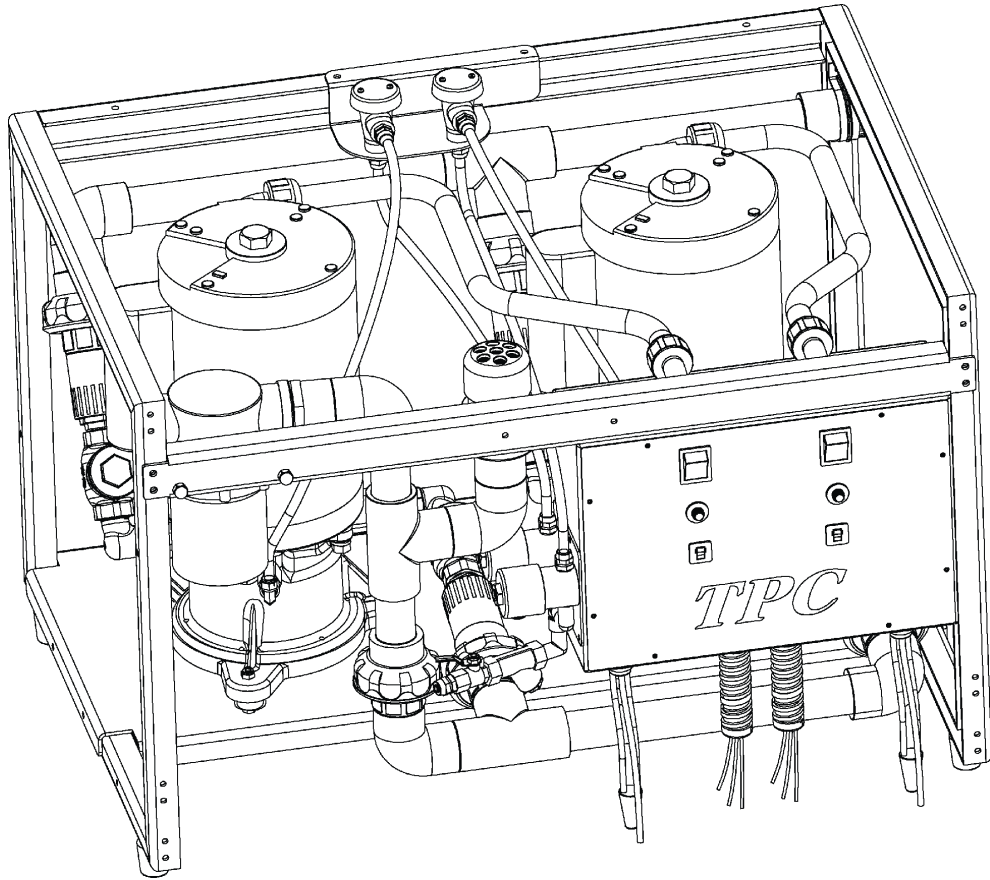

USER'S MANUAL

TPC *Advanced Technology, Inc.*

851 S. Lawson St
City of Industry CA 91748
800-560-8222
service@tpcdental.com
www.tpcdental.com

TABLE OF CONTENTS

SECTION	PAGE
Congratulations Warranty	2
Warranty	3
On-Line Warranty Registration	3
Sizing Guide	5
Product Specifications / Dimensions	5
Key Parts Identification	6
Installation Kits	6
Operating Information	7
Vacuum Relief Valve Adjustment	7
Vacuum Plumbing Recommended Layout	8
Electrical Connections	9
Site Requirements	10
Maintenance	11
Troubleshooting	12

CONGRATULATIONS

Congratulations on purchasing your new Superb Vac Dental Vacuum System. Your Superb Vac has been engineered to deliver maximum airflow at the ideal vacuum level without creating traumatic suction pressure that could harm patients' delicate tissue. The Superb Vac is a wet ring pump that produces consistent high-volume airflow, even with multiple users online. The balanced, corrosion-free bronze impeller minimizes noise, and a patented vacuum relief valve maintains constant uniform vacuum pressure. A start capacitor-type motor, with highly reliable electrical windings, and a powerful low-voltage transformer can be depended on to start, every time. The Superb Vac is designed with everything accessible from the front, including access to the solid collector.

If you purchased the optional Water Recycle Device & Air/Water Separator, water consumption will be reduced by up to 75%. The A/W separator separates the liquid and gas discharge from the operatories. The gasses are vented out while the liquid and its particulates are directed down the drain. The clean water extracted during this separation process is directed back toward the Superb Vac where it is mixed with fresh water and then directed into the pump chamber to create a vacuum. This efficient reuse of water reduces Superb Vac's freshwater consumption.

Now that your practice has a Superb Vac or a Superb Vac with the water-saving A/W Separator, you too can depend on constant, uniform delivery of vacuum to your operatories and proven trouble-free operation.

PURPOSE OF THIS MANUAL

This manual provides installation, operation, and maintenance instructions for the support of the six available Superb Vac systems listed below. Review and follow the guidelines included in this User Manual to ensure that the system provides the highest level of service.



WV3/ WV5

w/o Air Water Separator



WV6 / WV10



WV3/ WV5 with cabinet

WARRANTY

The Superb Vac is warranted to be free from defects in material and workmanship from the date of installation for 36 months.

Any item returned to our factory through a TPC Authorized Dealer will be repaired or replaced at our option at no charge provided that our inspection indicates it to have been defective. Dealer labor, shipping, and handling charges are not covered by this warranty. This warranty does not apply to damage due to shipping, misuse, careless handling, or repairs by other than authorized service personnel. Warranty is void if the equipment is installed or serviced by other than dealer service personnel authorized by TPC and is not liable for indirect or consequential damages or loss of any nature in connection with this equipment.

This warranty is in place of all other warranties expressed or implied. No representative or person is authorized to assume for us any liability in connection with the sale of our equipment.

ON-LINE WARRANTY REGISTRATION

Easily register your new Superb Vac online. Just have your product model and serial numbers available. Then go to www.tpcdental.com, click the FORMS tab, and select Register Equipment Serial Number. This online registration ensures a record for the warranty period and helps TPC keep you informed of product updates and other valuable information.



WARNING:

To prevent fire or electrical shock, do not expose this appliance to rain or moisture. All user-serviceable items are described in the maintenance section.

The manufacturing date code on the serial number label is in the format Month Year.

Personal Safety



Read the operator's instructions



Warning Shock Hazard



Warning High-temperature parts



Moving Parts

SIZING GUIDE

Choosing the correct size Superb Vac for your practice depends on the number of HVE (High Volume Evacuators) and SE (Saliva Ejector) users anticipated. To assure optimum vacuum, the vacuum demands should not exceed the number of HVE and SE users shown in the chart below:

Recommended Number of Simultaneous Users

Model	Recommended Number of Users	Number of Heads	Number of Motors
WV3	3	1	1
WV5	5	1	1
WV6	6	2	2
WV10	10	2	2

PRODUCT SPECIFICATIONS / DIMENSIONS

Specification / Model	WV3	WV5	WV6	WV10	WV3/cabinet	WV5/cabinet
Consumption w/o recycling	4L/min	4L/min	6L/min	6L/min	4L/min	4L/min
With TPC Water Recycling	0.8L/min	0.8L/min	1.0L/min	1.0L/min	0.8L/min	0.8L/min
Suction Rate	900L/min	1500L/min	1800L/min	3000L/min	900L/min	1500L/min
Max. Vacuum Level	-40Kpa	-60Kpa	-40Kpa	-60Kpa	-40Kpa	-60Kpa
Noise Level dB(A)	58	58	65	65	58	58
Horsepower	900W	1500W	1800W	3000W	900W	1500W
Voltage	110v / 220v	220v	220v	220v	220v	220v
Frequency	50 / 60Hz	50 / 60Hz	50 / 60Hz	50 / 60Hz	50 / 60Hz	50 / 60Hz
Support Users:	3	5	6	10	3	5
Current (A)	8A	13A	16A	26A	8A	13A
Circuit Breaker (A)	20A	20A	40A	40A	20A	20A
Inlet Connection Size	32mm	32mm	50mm	50mm	32mm	32mm
Drain Connection Size	32mm	32mm	32mm	32mm	32mm	32mm
City Water Connection Size	8mm	8mm	8mm	8mm	8mm	8mm
Air Exhaust Connection Size	50mm	50mm	50mm	50mm	50mm	50mm
Inlet Water Pressure (PSI)	Above 10PSI or 0.7bar					
Production Size:(L*W*H)mm	420x360x460	420x360x460	720x430x470	720x430x470	480x520x700	480x520x700

KEY PARTS IDENTIFICATION

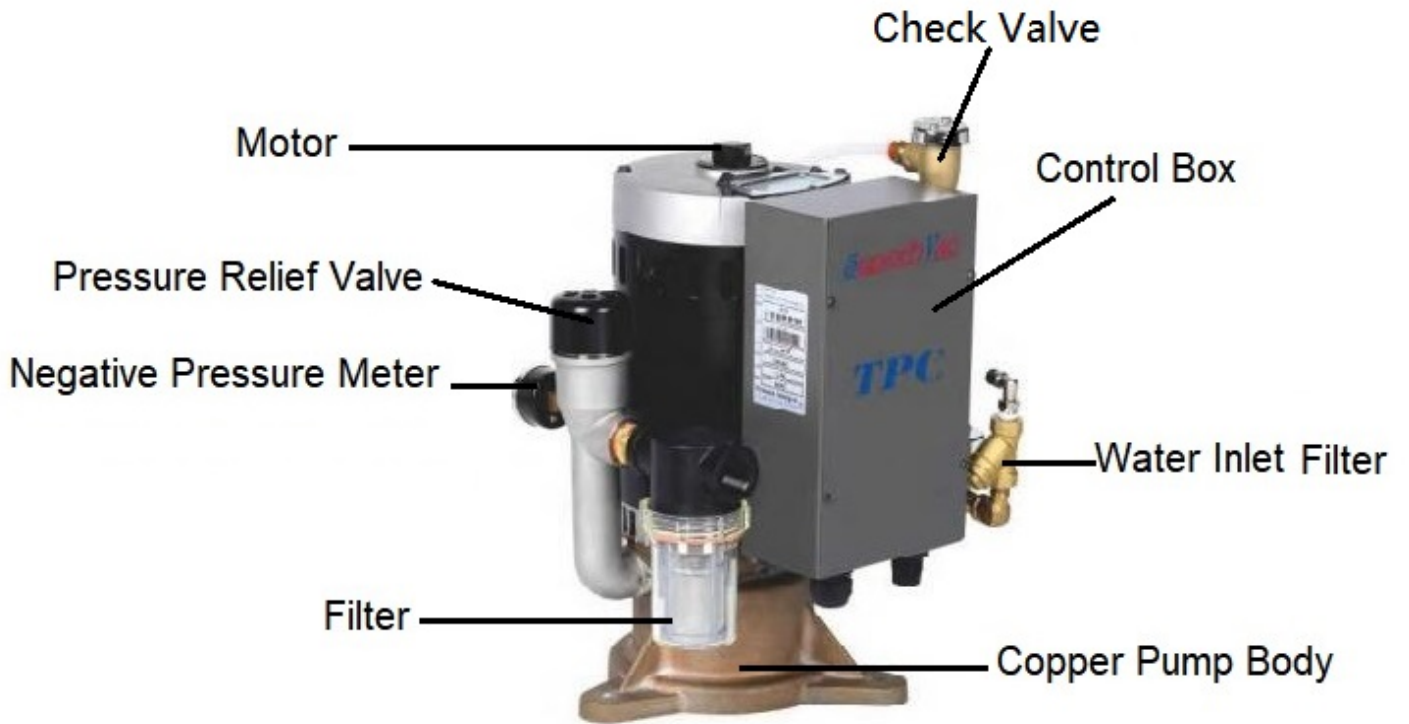

INSTALLATION KIT

Install Kits

Model: WV3, WV5

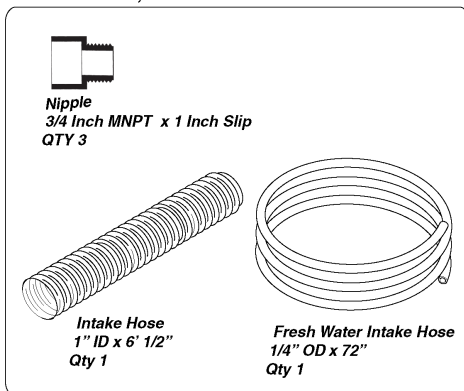

Model: WV6, WV10

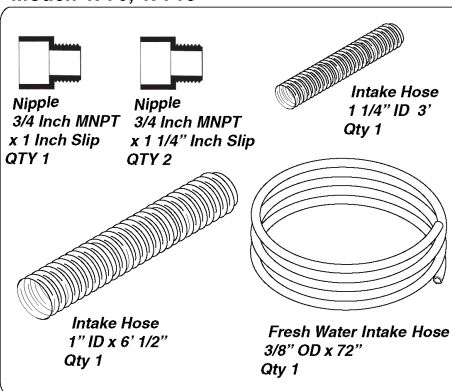

Model: X704-1009

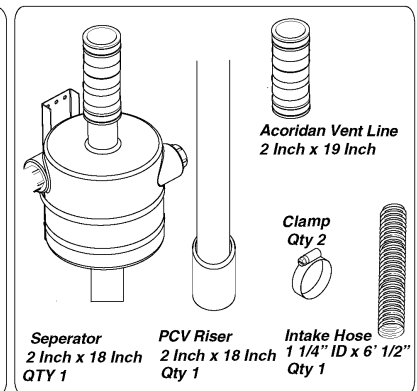

OPERATING INFORMATION

- AT THE START OF THE DAY
 - *Always TURN ON THE WATER before TURNING ON THE POWER*
- The Superb Vac may be turned on/off from a single, convenient location within the dental suite using a Remote-Control Panel. Or by toggling the main power switch (ON / OFF).
- The vacuum level is factory preset at 10 In Hg (inches of mercury). This is the reading on the gauge when all HVEs (High Volume Evacuator) and SEs (Saliva Ejectors) are CLOSED. Should this setting be too high for your needs, contact your dealer to adjust the setting.
- It is recommended that the system run continuously during the day. However, the Superb Vac can be turned off if suction is not required for 15 minutes or longer.
- If one pump is being operated at a time, it is important to alternate pumps on an every-other-day schedule so that the pumps are used evenly.
- AT THE END OF THE DAY Always TURN THE POWER OFF, then TURN THE WATER OFF.

VACUUM RELIEF VALVE ADJUSTMENT

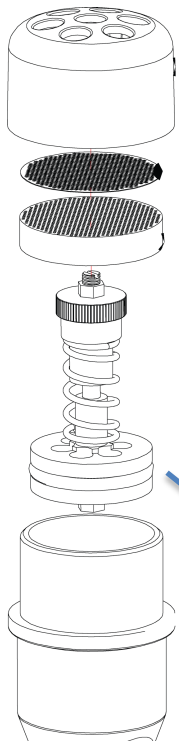

1. Remove relief valve cap.
2. Remove the screen.
3. Turn Adjustment knob clockwise to increase suction. Turn the adjustment knob counterclockwise to decrease the suction.
4. Inspect O-Ring for damage if adjustment not occurring.

*Always replace any O-ring with visible damage.

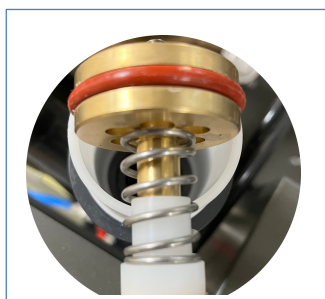

Wet-Ring Vacuum Site Requirement Layout

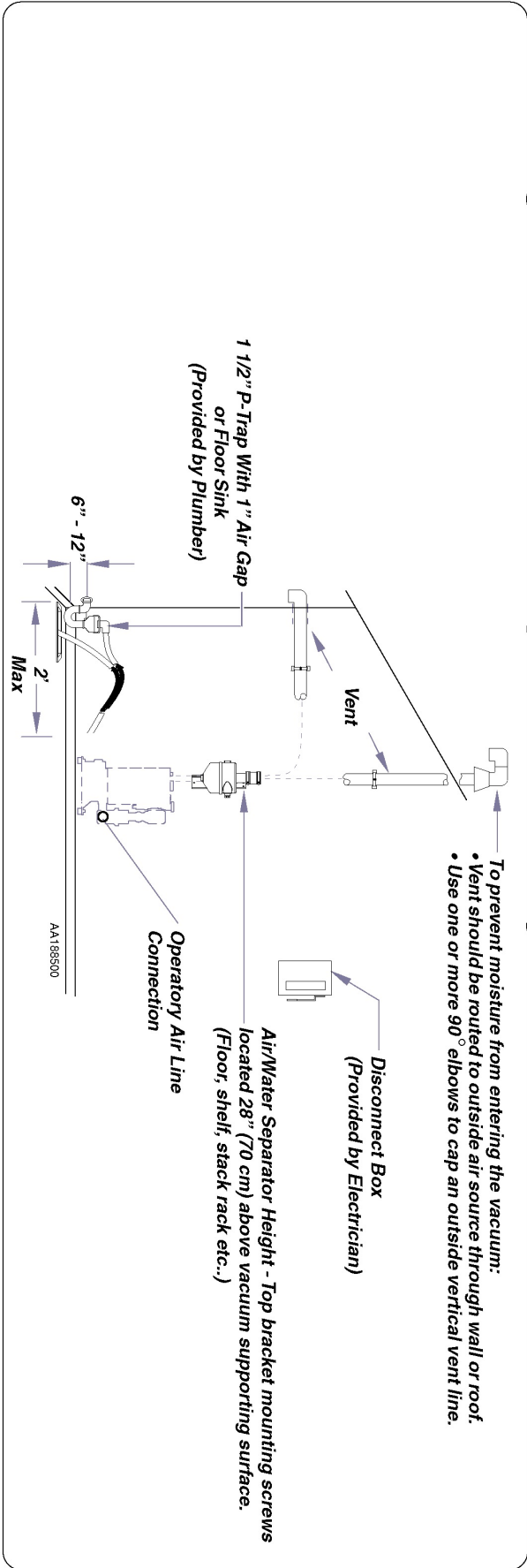

Equipment Alert
 When performing positive pressure leak tests to validate plumbing installation, verify vacuum systems are not connected to office piping.

VACUUM LINE SIZING CHART	
Number of Operatories Supplied Through Line	Main Line (PVC Sch 40) Pipe Diameter in Inches
1-2	3/4
3-4	1
5-6	1 1/4
7-10	1 1/2

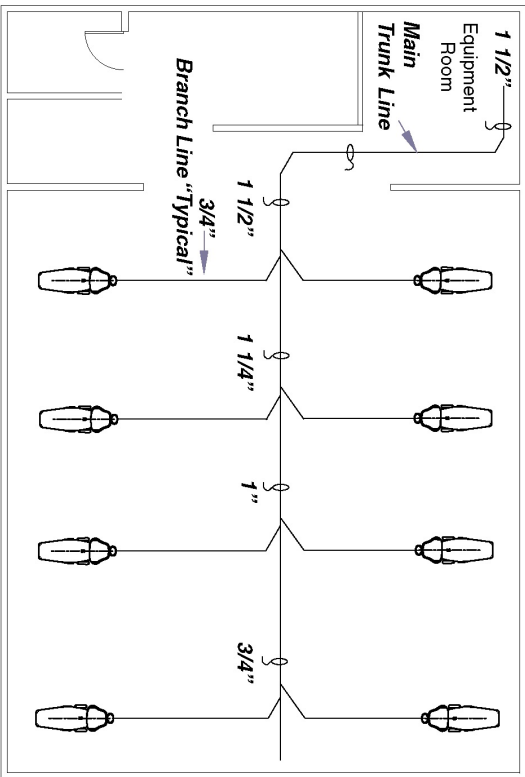

ELECTRICAL CONNECTIONS

110V Single Pump Connection:

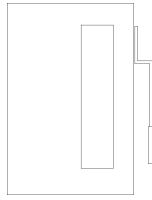
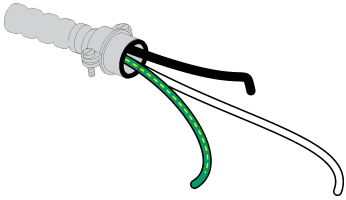

Wire Connections: 110V

Black – Hot

White – Neutral

Green – Ground

230V Single Pump Connection:

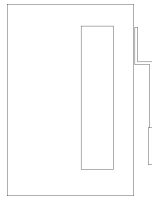
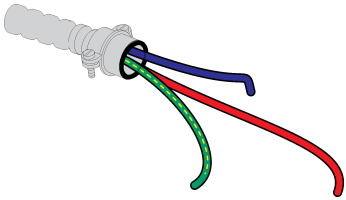

Wire Connections: 230V

Black – L1

White – L2

Green – Ground

230V Dual Pump Connection:

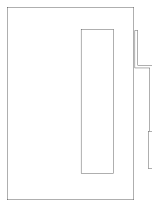
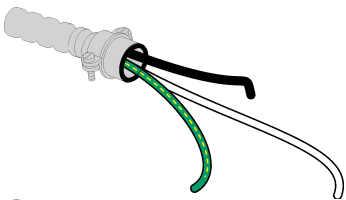

Wire Connections: 230V Dual Pump

Black – Hot

White – Neutral

Red – L1

Blue - L2

Green – Ground

Note: For Single Circuit. Connect Black, Red, and (L1) wires from the branch circuit together. Connect White, Blue, and (L2) wires from the branch circuit together. Green to Ground/Protective Earth wires from branch circuit together (**GND**)

24V Low Voltage Panel Connections

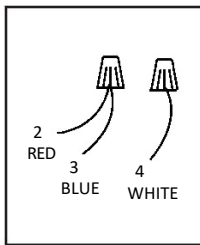

Note: For Single Circuit, connect Black, Red, and (L1) wires from the branch circuit together. Connect White, Blue, and (L2) wires from the branch circuit together. Connect Green to Ground/Protective Earth wire from branch circuit together (**GND**)

ATTENTION: Do not attempt to convert 110V motors terminals to 230V with 110V Water Solenoid installed. Low voltage taps need to be changed on 24 V transformer.

Low Voltage Panel

RED – HOT 24V

BLUE – RETURN

WHITE – COMMON / LIGHT.

SITE REQUIREMENTS

Environment/Operating Conditions:

Indoor use at altitudes up to 2000m

Temperature 5 to 40° C (41 to 104° F)

Maximum relative humidity 80% for temperatures up to 31° C

Decreasing linearly to 50% relative humidity at 40° C

Supply voltage fluctuation of +/- 10% of nominal voltage

Storage and Transport:

Temperature, -18 to 65°C (0 to 150°F). Relative Humidity, 0 to 90%

IEC 60601-1 Classification

Not suitable for use in the presence of a flammable anesthetics mixture with air or with oxygen or nitrous oxide.

Class I Installation Category

Ordinary equipment (IPX0)

Does not protect against the ingress of water.

The unit is suitable for continuous operation.

Single Models Air/Water Plumbing...

1. Mount Separator 28" (70 cm) above vacuum supporting surface.

2. Install exhaust silencer into 1" exhaust hose from vacuum to P-trap if applicable.

If not using an exhaust silencer...

3. Connect exhaust hose from vacuum to separator.

4. Connect 3/4" hose from separator to drain or P-trap.

5. Connect 2" PVC to top of separator and out to vent.

6. Connect 1/4" poly tube from vacuum to water supply.

7. Connect 3/4" NPT fitting and hose clamp from vacuum line to operator.

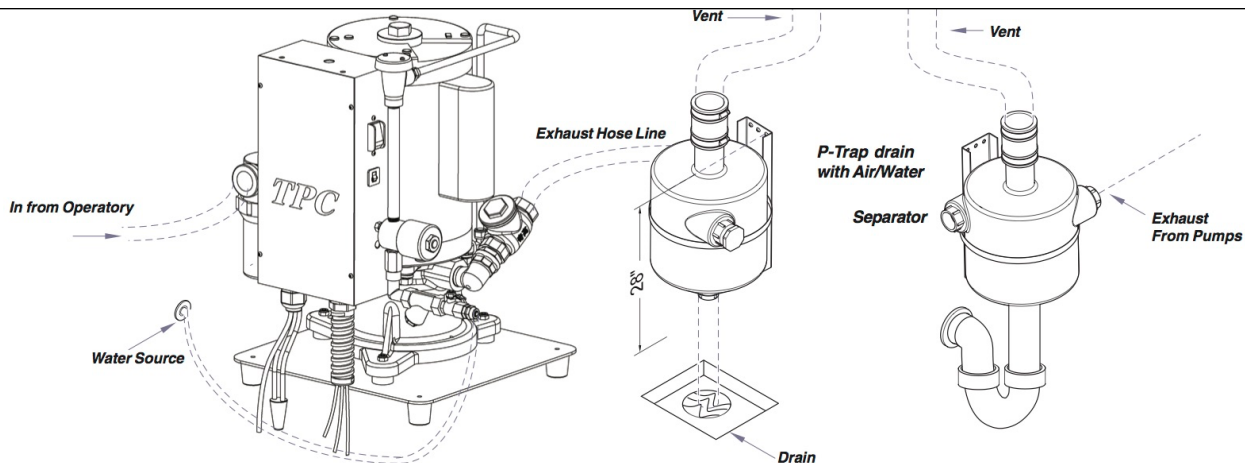

MAINTENANCE

Caution: Solids collector may contain biologically hazardous material. Wear protective gloves. Dispose of waste in an approved biohazard container.

Important: When a Superb Vac is replacing another vacuum pump, clean the collector DAILY during the first week of operation since larger quantities of particulates may initially occur.

A worn or missing gasket and/or failure to tightly screw the bowl to the solid's collector body will cause poor suction due to air leakage.



DO NOT OPERATE THE Superb Vac WITHOUT THE SCREEN INSIDE THE FILTER BOWL.

Intake Solids Collector Replacement – Monthly Refer to the below picture and use the replacement kit listed below for the specific Superb Vac models, replace the solids bowl, screen, and gasket. Do the same replacement if using an in-line filter.

Replacement Procedure

- Turn off the power and water supply.
- Unscrew the solids bowl (counter-clockwise) and remove the screen and gasket
Dispose of all three items
- Assemble a new bowl, screen, and gasket included in the Solids Collector Replacement Kit
- Install the new solids collector by screwing the bowl into the solid's collector body

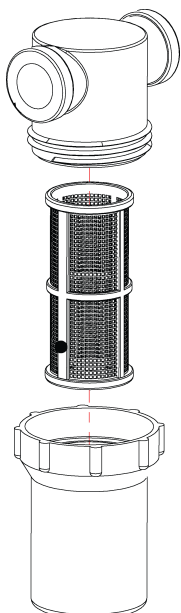

O-Ring
WV-RP-10-S Small 3/4" Filter
WV-RP-10-L Large 1" Filter

Filter:
WV-RP-VFA-G-S Small 3/4" Filter
WV-RP-VFA-G-L Large 1" Filter

Bowl:
WV-RP-11-S Small 3/4" Filter
WV-RP-11-L Large 1" Filter

Complete:
WV3-RP52
WV6-RP9



Check water filter annually. For locations with hard water deposits, inspect every 6 months. Clean or replace as needed.

Recycler Mode / Water Bypass Mode Settings.

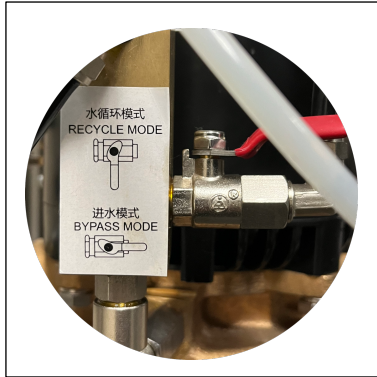

Recycle Mode: With the lever set horizontally to the valve body, the vacuum pump is in recycle mode.

Bypass Mode: With the lever set perpendicular to the valve body, the pump is in bypass mode.

The image to the left is in bypass mode.

TROUBLESHOOTING

PROBLEM	POSSIBLE CAUSE	POSSIBLE SOLUTIONS
1. Low suction. clogged.	<ul style="list-style-type: none"> a. Water filter or solids collector clogged. b. Check valve is stuck. c. Low water pressure. d. The A/W Separator water recycler is clogged. e. A/W Separator clogged. f. Solenoids not operating. g. Restricted air exhaust. 	<ul style="list-style-type: none"> a. Clean/replace the filter and/or collector. b. Use a system cleaner like Clean Stream; turn the vacuum on and off to free the check valve. If the valve remains stuck, call your authorized TPC dealer for repair service. c. Raise water pressure. d. Open the bypass valve to run Superb Vac. Call your authorized TPC dealer for repair service. e. Call your authorized TPC dealer for repair service. f. Open the bypass valve to run Superb Vac. Call your authorized TPC dealer for repair service. g. Check air exhaust pipe size to make sure it conforms to specification; check for and clear possible restrictions in the air exhaust system.
2. No suction.	<ul style="list-style-type: none"> a. Pumps off. b. Pumps not running. c. Inlet check valves stuck closed. d. Water inlet filter and/or solids collector clogged. e. Suction hose collapsed. f. Solenoids not operating. g. Water off. 	<ul style="list-style-type: none"> a. Turn pumps on. b. Call your authorized TPC dealer for repair service. c. Call your authorized TPC dealer for repair service. d. Clean/replace the filter. e. Hose needs to be replaced, call your authorized TPC dealer for repair service. f. Call your authorized TPC dealer for repair service. g. Turn the water on via the water inlet valve.
3. Excessive suction.	<ul style="list-style-type: none"> a. Relief valve stuck closed. b. Relief valve filter clogged. c. Relief valve set too high. 	<ul style="list-style-type: none"> a. Call your authorized TPC dealer for repair service. b. Call your authorized TPC dealer for repair service. c. Lower Relief valve setting.
4. Pumps do not run	<ul style="list-style-type: none"> a. Main circuit breakers off. b. Electrical problem. 	<ul style="list-style-type: none"> a. Turn main circuit breakers on. b. Call your authorized TPC dealer for repair service.
5. Noisy pumps.	<ul style="list-style-type: none"> a. Inadequate water supply. b. A/W Separator ejector clogged. c. Drain line collapsed. d. Solenoids not operating. 	<ul style="list-style-type: none"> a. Call a plumber to improve the water supply system. b. Call your authorized TPC dealer for repair service. c. Hose needs to be replaced. Call your authorized TPC dealer for repair service. d. Call your authorized TPC dealer for repair service.